

ExactLogic BACnet Communicating Thermostat

EXL01611 Sequence Datasheet

Air Handler Unit with 2 stage Cooling (with 1-5Vdc Digital Scroll) and 2 stage Heating



BACnet is a registered trademark of ASHRAE. ASHRAE does not endorse, approve or test products for compliance with ASHRAE standards. Compliance of listed products to requirements of ASHRAE Standard 135 is the responsibility of the BACnet International. BTL is a registered trademark of the BACnet International.



DataSheet Rev 1.12.310.4.0
April 22,2020

Operating Sequence

Standard Occupied

During normal occupied operation the display will show the current room temperature. The first press of either right pair of keys will show the current room setpoint. Additional presses will adjust the setpoint up or down by 0.5 degrees. The thermostat keypad will time out after 5 seconds without a key press, and the display will switch back to displaying the room temperature.

The left pair of keys allows for the adjustment of the fan speed. The current mode is shown with the first key press; additional key presses will show the adjustment to the mode. AV-62 is used to select the number of fan speeds (0 or 1 only), and AV-63 will show what speed the fan is currently set to (0-Off, 4-Auto or 5-On only). Refer to the table below for the values of AV-62 (Fan Mode Status) and AV-63 (Fan Speed Status)

AV-62	Mode
0	AUTO-ON
1	OFF-AUTO-ON
2	N/A
3	N/A
4	N/A
5	N/A

AV-63	Fan Speed
0	OFF
1	N/A
2	N/A
3	N/A
4	AUTO
5	ON

Internal/External Thermistor Control

The thermostat control sequence can use the internal thermistor or an external thermistor connected to AI-2. Setting BV-67 to OFF (default) the thermostat will use the internal thermistor. Setting BV-67 to ON the control sequence will use the external thermistor.

The current controlling temperature is located at AV-20. This value will be displayed on the LCD of the thermostat and should be used on any workstation displays.

Control Sequence – Heating

The occupancy of the thermostat is controlled by BO-5. When active the thermostat will maintain its occupied setpoint. The deadband is controlled by the heating offset (default 1 degree). As the room temperature drops below the heating setpoint the heating output will modulate from 0-100% and stage one will be engaged above 5%. Stage two will be engaged when the heating output rises above 55%. Stage two heating will disengage below 45%. Stage one heating will be disengaged at 0%.

Control Sequence – Cooling

The occupancy of the thermostat is controlled by BO-5. When active the thermostat will maintain its occupied setpoint. The deadband is controlled by the cooling offset (default 1 degree). As the room temperature rises above the cooling setpoint the modulating scroll cooling output will modulate from 0-100% (1-5Vdc adjustable). Stage two cooling will be engaged when the cooling control signal rises above 55% and the modulating scroll cooling output will modulate from 0-100% (1-5Vdc adjustable). Stage two cooling will disengage below 45%.

Note: All digital outputs have a 180 second ON/OFF anti-short cycle.

Standard Unoccupied

During unoccupied operation the thermostat will continue to display the room temperature. When in an unoccupied state pressing one of the right pair of keys will display a message indicating the thermostat is in night mode, preventing the setpoint from being adjusted. To adjust the room setpoint when unoccupied the thermostat must be set to night override.

Control Sequence

When in the unoccupied mode, the room will be controlled by the unoccupied cooling/heating setpoints. The fan and cooling and heating will operate the same as the occupied control sequence.

Night Override

Set the night override by pressing one of the left pair of keys. The display will switch to allow the user to set the night override time. Additional presses of the keys will adjust the time up or down by 0.5 hour increments. The night override can be increased up to the override limit set at AV-73, the default is 5 hours. When the thermostat is in night override, the first press of one of the left pair of keys will display the override time remaining. Additional key presses will add/subtract 0.5 hours to the time that was remaining. When the timer reaches zero the thermostat will return to the unoccupied mode.

In the night override mode, the right pair of keys can be used to adjust the room setpoint. The thermostat keypad will time out after 5 seconds without a key press, and the display will switch back to displaying the room temperature.

The thermostat can be set to a night override by writing a value to AV-74 through BACnet. The value can not exceed the night override limit set at AV-73. If the night override time is set higher than the limit, the night override timer will be set to the limit. The night override limit default is 5 hours.

If the thermostat is commanded to the occupied mode while in night override, the override timer will be cleared to zero and the thermostat will enter the occupied mode.

Control Sequence

When the thermostat is in the override mode, the room will be controlled by the occupied cooling/heating setpoints. The fan and cooling and heating will operate the same as the occupied control sequence.

Note: There is no fan control in the override mode. The fan will run in the AUTO mode.

Installation

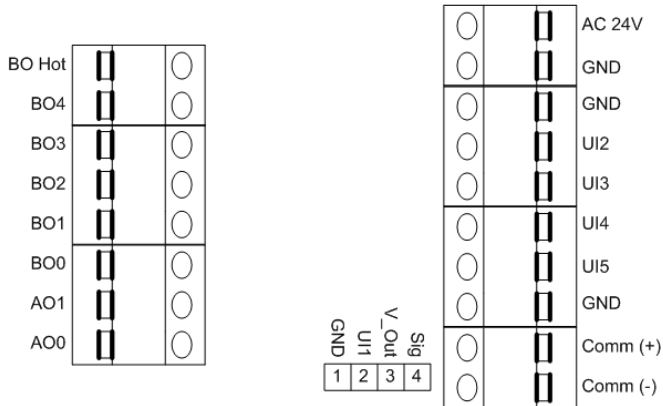

Fig. 4

*Note: Thermostat Common Relay point (BO Hot) usually 24VAC/DC or R

AC 24V 24VAC/DC Hot
 GND Neutral/Ground
 GND Neutral/Ground
 UI2 Universal Input 2
 UI3 Universal Input 3
 UI4 Universal Input 4
 UI5 Universal Input 5
 GND Neutral/Ground
 Comm (+) Network Positive Line
 Comm (-) Network Negative Line
 BO Hot Com, 24VAC Hot for relays*
 BO4 Relay 5 Output, 24VAC/DC
 BO3 Relay 4 Output, 24VAC/DC
 BO2 Relay 3 Output, 24VAC/DC
 BO1 Relay 2 Output, 24VAC/DC
 BO0 Relay 1 Output, 24VAC/DC
 AO1 Analog Output 1, 0-10V
 AO0 Analog Output 0, 0-10V

1 Neutral/Ground
 2 Universal Input 1
 3 Analog Output 2
 4 Reserved

Output Wiring

Output/Label	Heat / Cool Mode
BO0	Fan
BO1	Cooling Stage 1
BO2	Heating Stage 1
BO3	Cooling Stage 2
BO4	Heating Stage 2
AO0	Heating 0-5/10 Vdc 0-100%
AO1	Modulating Scroll Cooling 1-5 Vdc 0-50% & 50-100%

Reserved BACnet Points

The following are points reserved by the thermostat for operation.

Analog Inputs

Instance	Object Name	Description	Read/Write	Default
AI-0	Room Temp	Reading of the internal thermistor in counts. 0-1024	R	variable
AI-1	Humidity	Reading from the Humidity sensor add-on card	R	variable
AI-2	Ext. Room Temp	Optional external room temperature input	R	variable
AI-3	Analog Input 03	Reading of the external input 3 in counts. 0-1024	R	variable
AI-4	Analog Input 04	Reading of the external input 4 in counts. 0-1024	R	variable
AI-5	Analog Input 05	Reading of the external input 5 in counts. 0-1024	R	variable

Analog Outputs

Instance	Object Name	Description	Read/Write	Default
AO-0	Heat	0-5/10V output for control of heating	R/W	0.0
AO-1	Cool	1-5 output for Digital Scroll control of cooling	R/W	0.0

Analog Values

Instance	Object Name	Description	Read/Write	Default
AV-0	Mode of Operation	The mode that the thermostat is currently in. 0 = Heat Mode 1 = Cool Mode 2 = Idle 3 = Afterhours 4 = Unoccupied Idle 5 = Unoccupied Heat Mode 6 = Unoccupied Cool Mode	R	4
AV-1	Analog Value 001			
AV-2	Analog Value 002			
AV-3	Analog Value 003			
AV-4	Current Htg SP	The setpoint that controls heating. If the room temperature goes below this setpoint the thermostat will enter heating mode.	R	72.0 °F
AV-5	Current Clg SP	The setpoint that controls cooling. If the room temperature goes above this setpoint the thermostat will enter cooling mode.	R	74.0 °F
AV-6	Heating SP	The setpoint used for heating during occupied mode. This setpoint is calculated by AV-90 (Current SP) – AV-94 (Heating Offset)	R	72.0 °F
AV-7	Cooling SP	The setpoint used for cooling during occupied mode. This setpoint is calculated by AV-90 (Current SP) + AV-93 (Cooling Offset)	R	74.0 °F
AV-8	Heating Signal	Current heating signal as a percent	R	0%
AV-9	Cooling Signal	Current cooling signal as a percent	R	0%

AV-10	Analog Value 010			
AV-11	Analog Value 011			
AV-12	Analog Value 012			
AV-13	Analog Value 013			
AV-14	Analog Value 014			
AV-15	Analog Value 015			
AV-16	Analog Value 016			
AV-17	Analog Value 017			
AV-18	Analog Value 018			
AV-19	Analog Value 019			
AV-20	Room Temp	Selected from either AV-11 or AV-16. BV-85 is used for selection. This is the value displayed on the LCD of the thermostat and should be used to display the temperature on any workstation display.	R	variable
AV-21	Analog Value 021			
AV-22	Analog Value 022			
AV-23	Analog Value 023			
AV-24	Analog Value 024			
AV-25	Analog Value 025			
AV-26	Cooling Deviation	Number of degrees that the room temperature is away from the cooling setpoint	R	variable
AV-27	Heating Deviation	Number of degrees that the room temperature is away from the heating setpoint	R	variable
AV-28	Deviation from SP	Number of degrees that the room temperature is away from the room setpoint	R	variable
AV-29	Zone Scan	Numerical representation of the thermostats mode. 100 = full heat, -100 = full cool	R	0
AV-30	AI-0 Setup	Parameter used to set the input type. 0 = counts 1 = temperature 2 = 4-20mA 3 = 0-5V 4 = 0-10V 5 = pulse	R	1
AV-31	AI-1 Setup	See AV-30	R	0
AV-32	AI-2 Setup	See AV-30	R	0
AV-33	AI-3 Setup	See AV-30	R	0
AV-34	AI-4 Setup	See AV-30	R	0
AV-35	AI-5 Setup	See AV-30	R	0
AV-36	Analog Value 036			
AV-37	Analog Value 037			
AV-38	Analog Value 038			
AV-39	Analog Value 039			
AV-40	Heating Kp	Heating PI Controller Kp Factor	R/W	12
AV-41	Heating Ki	Heating PI Controller Ki Factor	R/W	1
AV-42	Cooling Kp	Cooling PI Controller Kp Factor	R/W	12
AV-43	Cooling Ki	Cooling PI Controller Ki Factor	R/W	1
AV-44	Dig Scroll Low V	AO-0 minimum output Volts where 0-100 = 0-10Vdc; Digital Scroll S/B set to 12 (1.2Vdc)	R/W	11
AV-45	Dig Scroll High V	AO-0 maximum output Volts where 0-100 = 0-10Vdc; Digital Scroll S/B set to max 50 (5 Vdc)	R/W	50

AV-46	Analog Value 046			
AV-47	Analog Value 047			
AV-48	Analog Value 048			
AV-49	Analog Value 049			
AV-50	Analog Value 050			
AV-51	Analog Value 051			
AV-52	Analog Value 052			
AV-53	Analog Value 053			
AV-54	Analog Value 054			
AV-55	Analog Value 055			
AV-56	Htg Interstage Delay	Time Delay for 2 nd Stage to be enabled after 1 st Stage has started	R/W	180 sec
AV -57	Clg Interstage Delay	Time Delay for 2 nd Stage to be enabled after 1 st Stage has started	R/W	180 sec
AV-58	Analog Value 058			
AV-59	Avg Time Base	Factor used to average the room temperature. A small number will allow the room temperature to change faster over time. A large number will cause the room temperature to change slower over time	R/W	100
AV-60	Int Sen Calibration	Internal Sensor Calibration Factor	R/W	0
AV-61	Space Alarm Offset	Space Sensor Alarm +/- Deadband	R/W	5°F
AV-62	# of Fan Speeds	Select the number of fan speeds for a multispeed fan. 0 = Auto Only 1 = AUTO - ON 2 = Off - AUTO - ON 3 = Off-1-2-AUTO 4 = Off-1-2-3-AUTO	R/W	0
AV-63	Current Fan Speed	The fan speed the thermostat is currently running. 0 = OFF 1 = Fan Speed 1 2 = Fan Speed 2 3 = Fan Speed 3 4 = AUTO 5 = ON	R	4
AV-64	Analog Value 064			
AV-65	Analog Value 065			
AV-66	Room Temp SP	Room Temperature Setpoint	R/W	73
AV-67	Occupied SP Hi Limit	The maximum occupied room setpoint allowed.	R/W	85.0°F
AV-68	Occupied SP Lo Limit	The minimum occupied room setpoint allowed	R/W	55.0°F
AV-69	Cooling Offset	Cooling Offset from Room Setpoint	R/W	1
AV-70	Heating Offset	Heating Offset from Room Setpoint	R/W	1
AV-71	Unocc Cooling SP	The Cooling Setpoint while Unoccupied	R/W	85
AV-72	Unocc Heating SP	The Heating Setpoint while Unoccupied	R/W	65
AV-73	After Hours Limit	The Maximum time for the After Hours Timer	R/W	5.0 H
AV-74	After Hours Timer	The time remaining on the After Hours Timer	R/W	0

AV-75	Analog Value 075			
AV-76	Analog Value 076			
AV-77	Analog Value 077			
AV-78	Analog Value 078			
AV-79	Analog Value 079			
AV-80	Analog Value 080			
AV-81	Analog Value 081			
AV-82	Analog Value 082			
AV-83	Splash Descriptor		R	0
AV-84	Analog Value 084			

AV-100	Analog Value 100	Internal thermistor display descriptor. The present value is automatically transferred. The AV description holds the descriptor to display.	R	variable
AV-101	Analog Value 101	Display descriptor. Transfer the value to display to the present value. The AV description holds the descriptor to display.	R/W	
AV-102	Analog Value 102	Display descriptor. Transfer the value to display to the present value. The AV description holds the descriptor to display	R/W	
AV-103	Analog Value 103	Display descriptor. Transfer the value to display to the present value. The AV description holds the descriptor to display	R/W	
AV-104	Analog Value 104	Display descriptor. Transfer the value to display to the present value. The AV description holds the descriptor to display	R/W	
AV-105	Analog Value 105	Display descriptor. Transfer the value to display to the present value. The AV description holds the descriptor to display	R/W	
AV-106	Analog Value 106	Display descriptor. Transfer the value to display to the present value. The AV description holds the descriptor to display	R/W	
AV-107	Analog Value 107	Display descriptor. Transfer the value to display to the present value. The AV description holds the descriptor to display	R/W	
AV-108	Analog Value 108	Display descriptor. Transfer the value to display to the present value. The AV description holds the descriptor to display	R/W	
AV-109	Analog Value 109	Display descriptor. Transfer the value to display to the present value. The AV description holds the descriptor to display	R/W	
AV-110	Analog Value 110	Display descriptor. Transfer the value to display to the present value. The AV description holds the descriptor to display	R/W	
AV-111	Analog Value 111	Display descriptor. Transfer the value to display to the present value. The AV description holds the descriptor to display	R/W	
AV-112	Analog Value 112	Display descriptor. Transfer the value to display to the present value. The AV description holds the descriptor to display	R/W	

Binary Inputs

Instance	Object Name	Description	Read/Write	Default
BI-0	Binary Input 00		R	
BI-1	Motion	Motion sensor status from the optional add-on card	R	
BI-2	Binary Input 02		R	
BI-3	Binary Input 03		R	
BI-4	Binary Input 04		R	
BI-5	Binary Input 05		R	

Binary Outputs

Instance	Object Name	Description	Read/Write	Default
BO-0	Fan	Output for Fan Control	R/W	OFF
BO-1	Cooling Stage 1	Cooling Stage 1	R/W	OFF
BO-2	Heating Stage 1	Heating Stage 1	R/W	OFF
BO-3	Cooling Stage 2	Cooling Stage 2	R/W	OFF
BO-4	Heating Stage 2	Heating Stage 2	R/W	OFF
BO-5	Scheduled Occupied	Logical point only. Used for scheduling purposes. OFF is unoccupied.	R/W	ON

Binary Values

Instance	Object Name	Description	Read/Write	Default
BV-0	Bad Sensor Alarm	Alarm for a bad internal thermistor	R	OFF
BV-1	H/C Mode	Sequence point to show analog heating or cooling. OFF = Cooling ON = Heat	R	OFF
BV-2	Binary Value 002			
BV-3	Binary Value 003			
BV-4	Binary Value 004			
BV-5	Binary Value 005			
BV-6	Binary Value 006			
BV-7	Binary Value 007			
BV-8	Binary Value 008			
BV-9	Space Alarm Delay	Delay used to prevent a space alarm after receiving an occupied command. The delay is 7200 sec	R	OFF
BV-10	Program Status	Used to determine if the sequence was loaded correctly on a BACnet Restore or power up.	R	OFF
BV-11	Binary Value 011			
BV-12	Binary Value 012			
BV-13	Binary Value 013			
BV-14	Binary Value 014			
BV-15	Binary Value 015			
BV-16	Binary Value 016			
BV-17	Binary Value 017			
BV-18	Binary Value 018			

BV-19	Binary Value 019			
BV-20	Binary Value 020			
BV-21	Binary Value 021			
BV-22	Too Warm Status	Status of the Too Warm Alarm before checking the Space Alarm Delay	R	OFF
BV-23	Too Cool Status	Status of the Too Warm Alarm before checking the Space Alarm Delay	R	OFF
BV-24	Space To Warm Alarm	The space temperature has been below the Room Set point (AV-90) – Space Alarm Offset (AV-82) for at least 7200 seconds.	R	OFF
BV-25	Space To Cool Alarm	The space temperature has been above the Room Set point (AV-90) + Space Alarm Offset (AV-82) for at least 7200 seconds.	R	OFF
BV-26	Heat Stage 1 Status	The status of the stage 1 Heat request before the 180 second anti-short cycle delay.	R	OFF
BV-27	Cool Stage 1 Status	The status of the stage 1 Cool request before the 180 second anti-short cycle delay.	R	OFF
BV-28	Heat Stage 2 Status	The status of the stage 2 Heat request before the 180 second anti-short cycle delay.	R	OFF
BV-29	Cool Stage 2 Status	The status of the stage 2 Cool request before the 180 second anti-short cycle delay.	R	OFF
BV-30	Binary Value 030			
BV-31	Binary Value 031			
BV-32	Binary Value 032			
BV-33	Binary Value 033			
BV-34	Binary Value 034			
BV-35	Binary Value 035			
BV-36	Binary Value 036			
BV-37	Binary Value 037			
BV-38	Binary Value 038			
BV-39	Binary Value 039			
BV-40	Occupied Status	The status of this point switches the thermostats occupancy settings. When ON, the thermostat is in Occupied Setpoint Mode or After Hours Mode.	R	ON
BV-41	Opt. Start Warmup	A Warmup command has been sent to the thermostat. When ON the thermostat will switch to occupied settings.	R/W	OFF
BV-42	Opt. Start Cooldown	A Cooldown command has been sent to the thermostat. When ON the thermostat will switch to occupied settings.	R/W	OFF
BV-43	Occ Set point Mode	The thermostat has been commanded occupied via BO-5, or a Warmup/Cooldown command has been sent via BV-41/BV-42.	R	ON
BV-44	After Hours Status	The thermostat has been set to after hours mode. When ON the thermostat will switch to occupied settings.	R	OFF
BV-45	Binary Value 045			
BV-46	Binary Value 046			

BV-47	Binary Value 047			
BV-48	Binary Value 048			
BV-49	Update Descriptors	When ON descriptor changes are sent to the thermostats LCD, this point will auto reset to OFF.	R/W	OFF
BV-50	Binary Value 050			
BV-51	Binary Value 051			
BV-52	Binary Value 052			
BV-53	Binary Value 053			
BV-54	Binary Value 054			
BV-55	Binary Value 055			
BV-56	Binary Value 056			
BV-57	Disable Splash	Disables the Splash Screen	R/W	OFF
BV-58	Disable Setup Menu	Disables the Setup Menu	R/W	OFF
BV-59	Disable FSM Menu	Disables the Field Service Menu	R/W	OFF
BV-60	Binary Value 060			
BV-61	Binary Value 061			
BV-62	Binary Value 062			
BV-63	Binary Value 063			
BV-64	Enable Motion	Reserved – used with optional motion sensor	R	OFF
BV-65	Binary Value 065			
BV-66	Disable Unit	Disables all outputs from the Thermostat	R/W	OFF
BV-67	Room Temp Select	ON = Select the external thermistor, AI-2, for the control sequence OFF = Select the internal thermistor, AI-0, for the control sequence	R/W	OFF
BV-68	Backlight On	Turns the Backlight ON	R/W	OFF
BV-69	Fan Cycle Mode	Controls if the fan will cycle or run continuously. OFF = Cycle, ON = Continuous, BV-40 must also be ON.	R/W	OFF
BV-70	Binary Value 070			
BV-71	C/F	Sets the thermostat to display temperatures in Celsius or Fahrenheit. This point is set through the setup menu. ON = F, OFF = C	R	ON
BV-72	Binary Value 072			
BV-73	Binary Value 073			
BV-74	Binary Value 074			

BV-100	Binary Value 100	Enable internal thermistor descriptor	R/W	ON
BV-101	Binary Value 101	Enable descriptor	R/W	OFF
BV-102	Binary Value 102	Enable descriptor	R/W	OFF
BV-103	Binary Value 103	Enable descriptor	R/W	OFF
BV-104	Binary Value 104	Enable descriptor	R/W	OFF
BV-105	Binary Value 105	Enable descriptor	R/W	OFF
BV-106	Binary Value 106	Enable descriptor	R/W	OFF
BV-107	Binary Value 107	Enable descriptor	R/W	OFF
BV-108	Binary Value 108	Enable descriptor	R/W	OFF
BV-109	Binary Value 109	Enable descriptor	R/W	OFF
BV-110	Binary Value 110	Enable descriptor	R/W	OFF
BV-111	Binary Value 111	Enable descriptor	R/W	OFF
BV-112	Binary Value 112	Enable descriptor	R/W	OFF